

SERIES SD

OPERATION

The Slot Dipping Device (Figure 5074) has been designed to provide a convenient and safe means of manually measuring the levels and taking samples of petroleum, petrochemical, chemical and other volatile or hazardous liquids in bulk storage tanks, in pressures of up to 40" (1016 mm) WG. It is available in 6" (150 mm) size and is mounted on the roofs of tanks and can be used in place of conventional gauge hatches with the following advantages :

- Negligible loss of vapour
- Operators not exposed to hazardous vapours
- No product spillage due to wiping of the tape

The Temperature and Sampling Device has been designed to provide a means of taking samples of products stored in bulk in the petroleum, petrochemical, chemical and allied industries. When used in conjunction with the Slot Dipping Device which is suitable for pressures up to 40" (1016 mm) WG, loss of vapour is greatly reduced.

SERVICING

All tank environmental protection equipments can be supported by our service department who can be supported by our service department who can provide expert and specialist installation and commissioning service and complete 'on site' equipment maintenance, repair and servicing facilities including equipment condition surveying and certification and maintenance training.



SLOT DIPPING DEVICE AND ADAPTORS - 6" (150mm)

CONSTRUCTION

The assembly consists of an upper and lower body section with a counter balanced lever operated closing pallet in the lower section. The upper section is sized to accommodate the dip weight or sampling device when the isolating pallet in the lower section is closed. The hinged cap closing the upper section is constructed to accept the bayonet fitting of the rope or tape adaptor. When the fitting is not in use it is closed by a sealing plug. The main components - body sections, cap and closure pallet are constructed in Aluminium alloy.

MOUNTING

The lower body section is drilled to ASA 150.

OPERATION

Hand Gauging

Tape Adaptor (Fig.5074-89) has a small clearance around the tape through which only a very small amount of vapour can escape and is permanently attached to the tape. When the upper section of the device is isolated from the tank by the closure pallet the plug can be removed and the tape weight inserted with the tape adaptor replacing the plug. Gauging can proceed when closure pallet has been lowered. Indicating paste is normally used when gauging spirit tanks. When gauging black oil tanks it is advisable to use the Fig.5074-88 adaptor which incorporates a tape wiper. A hard Beryllium copper strip in the adaptor holds the graduated side of the tape clear of the edge of the slot. The aperture in the upper section cap is 46 mm diameter and will allow passage of all known standard tape weights and the plunger of the Figure 1215 Portable Temperature Sensor.

SAMPLING

Either a gauging tape or a PVC covered wire rope can be used with the corresponding adaptor. The method of sampling follows closely that for gauging except that the cap on the upper chamber is opened and the sampling device (Fig.3419) is placed in the upper section and the tape/rope connected. The tape adaptor (Fig. 5074-89) or rope adaptor (Fig. 5074-90) is inserted in the cap and after lowering the pallet, sampling can proceed.

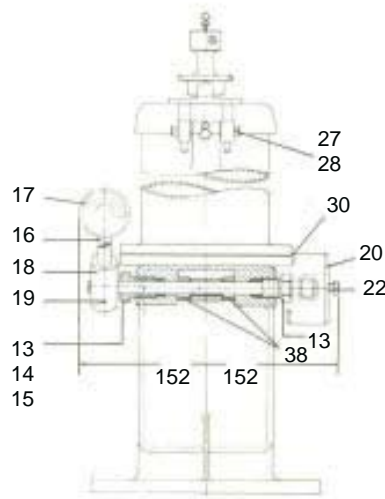
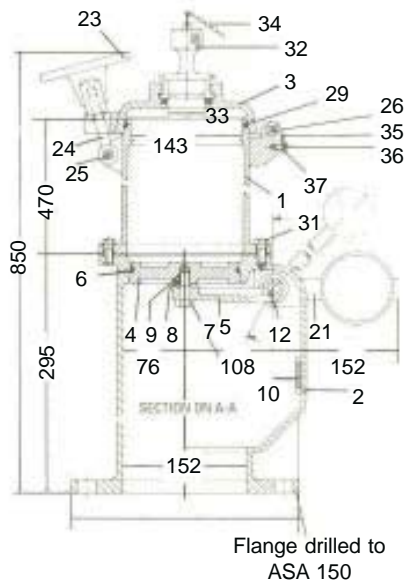

Dip Tape Adaptor
(Fig. 5074-89)



Tape Adaptor
with Wiper
(Fig. 5074-88)



Rope Adaptor
(Fig. 5074-90)

Sr. No.	Part Description	Matl.	Qty.
1	Body (Upper Section)	Alu	1
2	Body (Lower Section)	Alu	1
3	Cap	Alu	1
4	Pallet	Alu	1
5	Pallet Arm	SS	1
6	Pallet O'Ring	SR	1
7	Screw	SS	1
8	Pallet Washer	SS	1
9	Screw	CPS	1
10	Pallet Arm Stop	SR	1
11	Pallet Shaft	SS	1
12	Shaft Key	MS	1
13	Gland Nut	Brass	2
14	Gland Washer	Brass	1
15	Gland Packing	AFM	2
16	Pallet Operating Handle	CPS	1
17	Handle Ball	CI	1
18	Handle Socket	CPS	1
19	Mills Pin	MS	2
20	Counterweight	CI	1
21	Counterweight Lever	Brass	1
22	Screw	CPS	1
23	Clamping Nut	Brass	1
24	Eyebolt	CPS	1
25	Eyebolt Spindle	Brass	1
26	Cap Spindle	Brass	1
27	Washer	Brass	4
28	Cotter Pin	Brass	4
29	'O' Ring for Cap	SR	1
30	Body Gasket	AFM	1
31	Screw	CPS	8
32	Sealing Plug	Alu	1
33	Plug Seating	SR	1
34	Plug Retaining Chain	Brass	1
35	'S' Ring for Chain	Brass	1
36	Screw	SS	1
37	Washer 1/4"	SS	1
38	Distance Piece	Alu	2

MS	Mild Steel
SS	Stainless Steel
SR	Synthetic Rubber
AFM	Asbestos Free Material
CPS	Cadmium Planted Mild Steel
CI	Cast Iron
Alu	Aluminium Alloy LM-25

FIG. 3419 SAMPLING AND TEMPERATURE DEVICE (OPTIONAL)

CONSTRUCTION

The unit consists of a sample container which can be opened and closed beneath the liquid surface by the thermometer containment tube which is attached to a rope or graduated tape (see diagram). The materials are predominantly Stainless Steel and Brass.

OPERATION

The case is opened by raising the outer body (8) with respect to the lower end cover (11). After preliminary flushing at the required depth, the device is closed and the sample trapped by jerking the rope or tape which supports the device.

Temperature variation during the time taken to raise the sample and read the thermometer is negligible, because the body (8) and disc (10) insulate the sample from its surroundings. When the temperature has been read, the sample may either be returned to the tank or decanted into a sampling bottle using the special funnel (20). A flushing time of not more than 30 seconds is required for most unheated petroleum products. Heated viscous oils may require a slightly longer immersion of up to 1 minute.

MAIN FEATURES

1. Conforms with the requirements of Institute of Petroleum Measurement Manual Part IV Section 3.7.
2. Will accommodate thermometers manufactured to the Institute of Petroleum Specification with overall and immersed lengths of 340 mm and 65 mm respectively.
3. Samples and Temperatures can be taken at various depths of product including from a layer within 4" (100 mm) of tank bottom.
4. Sample volume is 0.4 litres (0.7 pts, 25 in³).

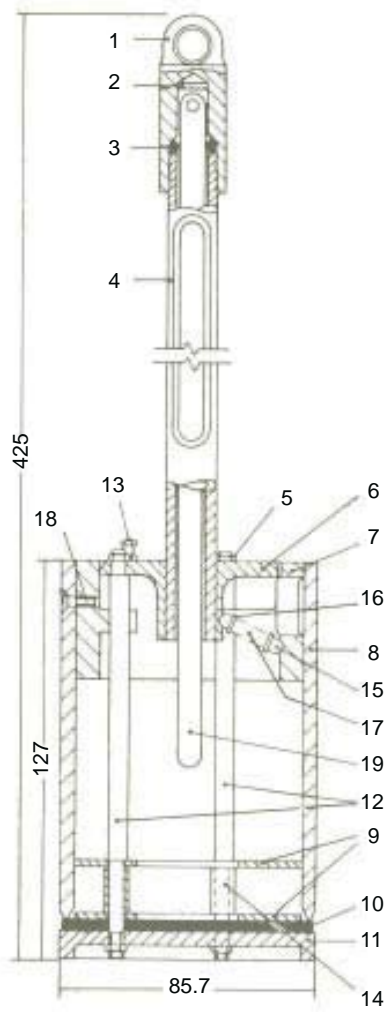

Sr. No.	Part Description	Matl.
1	Cap	Brass
2	Disc	SR
3	Ring	SR
4	Tube	Brass
5	Nuts No.8	SS
6	Top Cove	Brass
7	Guide	Brass
8	Body	Plastic
9	Plate	Brass
10	Seet	SR
11	Bottom Cover	Brass
12	Guide Rod	SS
13	Adjusting Screw	SS
14	Spacer	Brass
15	Pin Male	SS
16	Pin Female	SS
17	Spring	SS
18	Screw No.8	Brass
19	Thermemeter	
20	Aluminium Decanting	

Funnel Rope & Hook; P.V.C. covered S.S. wire, length as ordered; Brass Hook

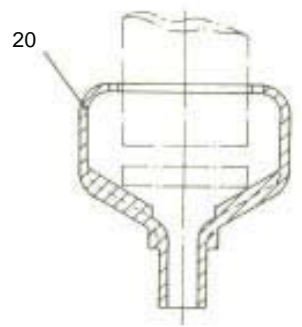

SPECIFICATIONS

Slot Dipping Device

Model : Figure 5074
Size : 150 mm (6")
Mounting Flange : 6" ASA 150 FF

MATERIALS OF CONSTRUCTION

Body, Base & Cover : Aluminium LM-25
Lever, Handle : Refer parts list
Sealing Ring : Nitrile

